



KITZ Corporation Of America  
800-772-0073 • www.KITZ.com

**BUTTWELD CARBON STEEL BALL VALVE**  
Three Piece • Regular Port • Stainless Steel Trim • Hypatite Seats  
ISO 5211 Mounting Pad (KITZ Standard Mounting Pad on 1/2")  
Lockable Lever Handle • Firesafe in Accordance with API 607  
Encapsulated Body Bolts • 1000 WOG • Schedule 40 Ends • NACE

Steel Ball Valves

**BWU3THZM-FS**  
**CODE NO. 329B**

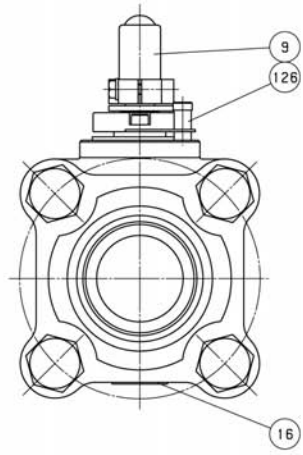
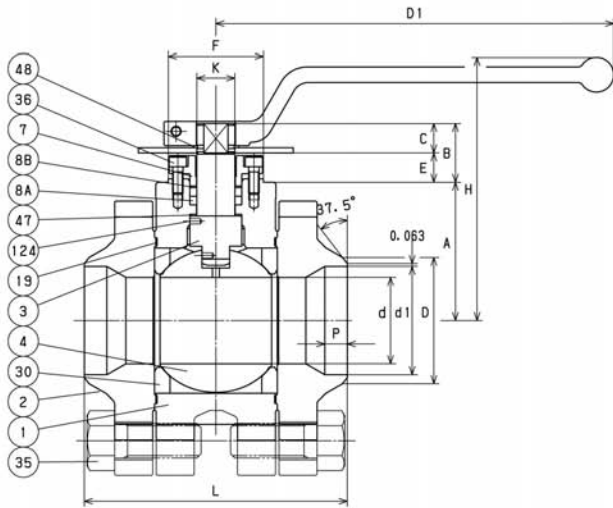
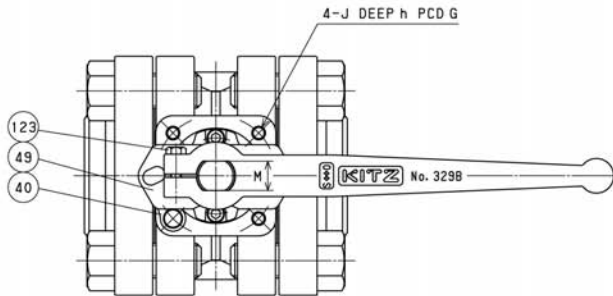

**MATERIAL LIST**

No.	Name of Parts	Materials
1	BODY	A351 Gr. CF8M
2	CAP	A351 Gr. CF8M
3	STEM	A276 TYPE 316
4	BALL	A351 Gr. CF8M
7	GLAND	A351 Gr. CF8
8A	GLAND PACKING	FLEXIBLE GRAPHITE
8B	SPACER PACKING	G/F PTFE
9	HANDLE	DUCTILE IRON
16	NAME PLATE	STAINLESS STEEL
19	GASKET	(2)
30	BALL SEAT	HYPATITE PTFE
35	CAP BOLT	A193 Gr. BB
36	GLAND BOLT	A193 Gr. BB
40	KEY LOCK PLATE	STAINLESS STEEL
47	THRUST WASHER	25% CARBON FILLED PTFE (1)
48	SNAP RING	STAINLESS STEEL
49	STOPPER	STAINLESS STEEL
123	HANDLE BOLT	STAINLESS STEEL
124	SPRING & PIN	A313 & A276 TYPE 316
126	STOPPER PIN	STAINLESS STEEL

**NOTE**

- (1) All valves have an anti-static thrust washer insuring positive conductivity between body and stem.
- (2) Flexible graphite with stainless foil insert.

**DIMENSIONS**

Nominal Size	Welding End															Mounting Dimensions for Actuator					ISO 5211 Flange Type	
	d	H	D1	L	d1	D	P	A	B	C	E	F	K	G	J	h	M	F07				
2 1/2	50	152	230	152	63	73	13	80	34	17	17	55	22	70	3/16-18UNC	15	17	F07				

Nominal Size	Welding End															Mounting Dimensions for Actuator					ISO 5211 Flange Type	
	d	H	D1	L	d1	D	P	A	B	C	E	F	K	G	J	h	M	F07				
2 1/2	1.97	5.98	9.06	5.98	2.469	2.874	0.512	3.150	1.339	0.669	0.669	2.165	0.866	2.756	3/16-18UNC	0.591	0.669	F07				

Unit : mm

Unit : inch