



KITZ Corporation Of America
800-772-0073 • www.KITZ.com

BUTTWELD CARBON STEEL BALL VALVE
Three Piece • Regular Port • Stainless Steel Trim • Hypatite Seats
ISO 5211 Mounting Pad (KITZ Standard Mounting Pad on 1/2")
Locking Oval Handle • Firesafe in Accordance with API 607
Encapsulated Body Bolts • 1500 WOG • Schedule 40 Ends • NACE

Steel Ball Valves

BWU3THZM-FSO
CODE NO. 329B-LOH

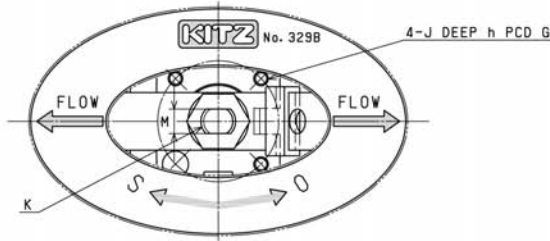

MATERIAL LIST

No.	Name of Parts	Materials
1	BODY	A351 Gr. CF8M
2	CAP	A351 Gr. CF8M
3	STEM	A276 TYPE 316
4	BALL	A276 TYPE 316 or A351 Gr. CF8M
7	GLAND	A276 TYPE 316
8A	GLAND PACKING	FLEXIBLE GRAPHITE
8B	SPACER PACKING	G/F PTFE
9	HANDLE	A276 TYPE 430 (1)
10	HANDLE NUT	A194 Gr. 8
16A	WASHER	STAINLESS STEEL
16B	NAME PLATE	STAINLESS STEEL
19	GASKET	FLEXIBLE GRAPHITE
30	BALL SEAT	HYPATITE PTFE
34	GLAND NUT	A194 Gr. 8
35	CAP BOLT	A193 Gr. 8B
40	LOCK PLATE	STAINLESS STEEL
43	CONED DISC SPRING	STAINLESS STEEL
47	THRUST WASHER	25% CARBON FILLED PTFE (2)
126	STOPPER PIN	A276 TYPE 304
A	LATCH LOCK	STAINLESS STEEL

NOTE

- (1) Plastic covering.
- (2) All valves have an anti-static thrust washer insuring positive conductivity between body and stem.

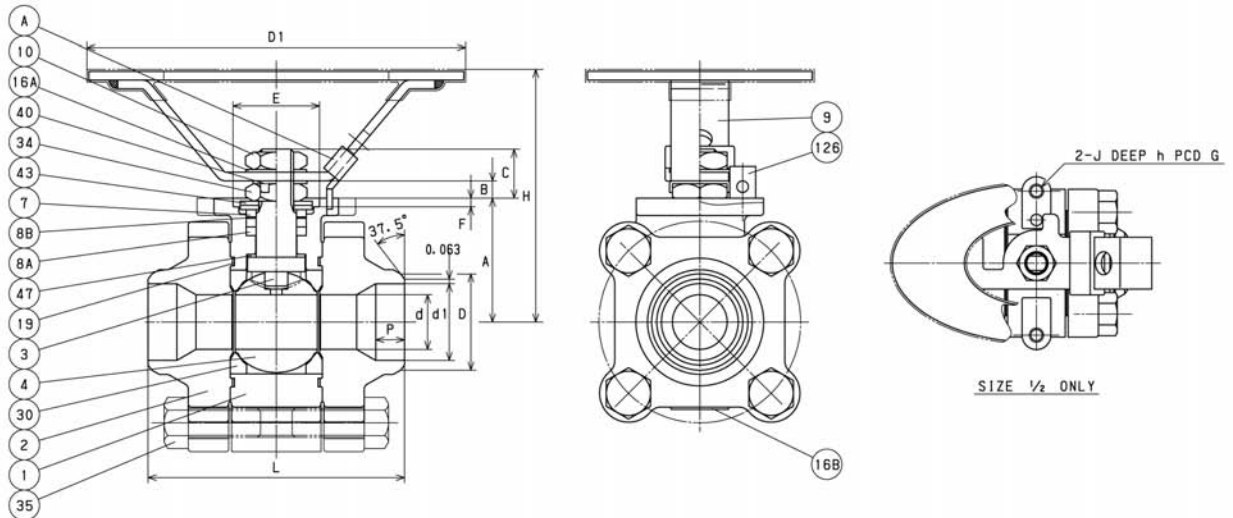

DIMENSIONS

Unit : mm

Nominal Size	Welding End										Mounting Dimensions for Actuator										ISO 5211 Flange Type
	in.	d	H	D1	L	d1	D	P	A	B	C	E	F	G	J	h	K	M			
1/2	10	63	100	63	16	21	6	26	2	10	—	—	50	1/4-20UNC	7	M8	5	—			
3/4	14	78	130	70	21	27	7	35	4	14	25	3	36	1/4-20UNC	5	M10	6	F03			
1	19	87	130	89	27	33	10	43	5	17	30	3	42	1/4-20UNC	8	M12	9	F04			

Unit : inch

Nominal Size	Welding End										Mounting Dimensions for Actuator										ISO 5211 Flange Type
	in.	d	H	D1	L	d1	D	P	A	B	C	E	F	G	J	h	K	M			
1/2	0.39	2.48	3.94	2.48	0.620	0.839	0.236	1.043	0.079	0.413	—	—	1.969	1/4-20UNC	0.275	M8	0.197	—			
3/4	0.55	3.07	5.12	2.76	0.825	1.051	0.276	1.378	0.169	0.559	0.984	0.118	1.417	1/4-20UNC	0.197	M10	0.236	F03			
1	0.75	3.43	5.12	3.50	1.049	1.315	0.394	1.693	0.197	0.669	1.181	0.118	1.654	1/4-20UNC	0.315	M12	0.335	F04			



KITZ Corporation Of America
800-772-0073 • www.KITZ.com

BUTTWELD CARBON STEEL BALL VALVE
Three Piece • Regular Port • Stainless Steel Trim • Hypatite Seats
ISO 5211 Mounting Pad (KITZ Standard Mounting Pad on 1/2")
Locking Lever Handle • Firesafe in Accordance with API 607
Encapsulated Body Bolts • 1500 WOG • Schedule 40 Ends • NACE

Steel Ball Valves

BWU3THZM-FS
CODE NO. 329B

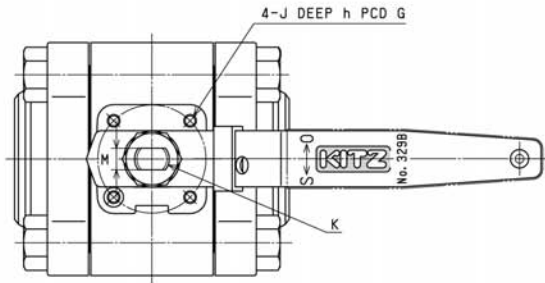

MATERIAL LIST

No.	Name of Parts	Materials
1	BODY	A351 Gr. CF8M
2	CAP	A351 Gr. CF8M
3	STEM	A276 TYPE 316
4	BALL	A276 TYPE 316 or A351 Gr. CF8M
7	GLAND	A276 TYPE 316
8A	GLAND PACKING	FLEXIBLE GRAPHITE
8B	SPACER PACKING	G/F PTFE
9	HANDLE	A276 TYPE 430 (1)
10	HANDLE NUT	A194 Gr. 8
16A	WASHER	STAINLESS STEEL
16B	NAME PLATE	STAINLESS STEEL
19	GASKET	FLEXIBLE GRAPHITE
30	BALL SEAT	HYPATITE PTFE
34	GLAND NUT	A194 Gr. 8
35	CAP BOLT	A193 Gr. B8
40	LOCK PLATE	STAINLESS STEEL
43	CONED DISC SPRING	STAINLESS STEEL
47	THRUST WASHER	25% CARBON FILLED PTFE (2)
126	STOPPER PIN	A276 TYPE 304
A	LATCH LOCK	STAINLESS STEEL

NOTE

- (1) Plastic covering.
- (2) All valves have an anti-static thrust washer insuring positive conductivity between body and stem.

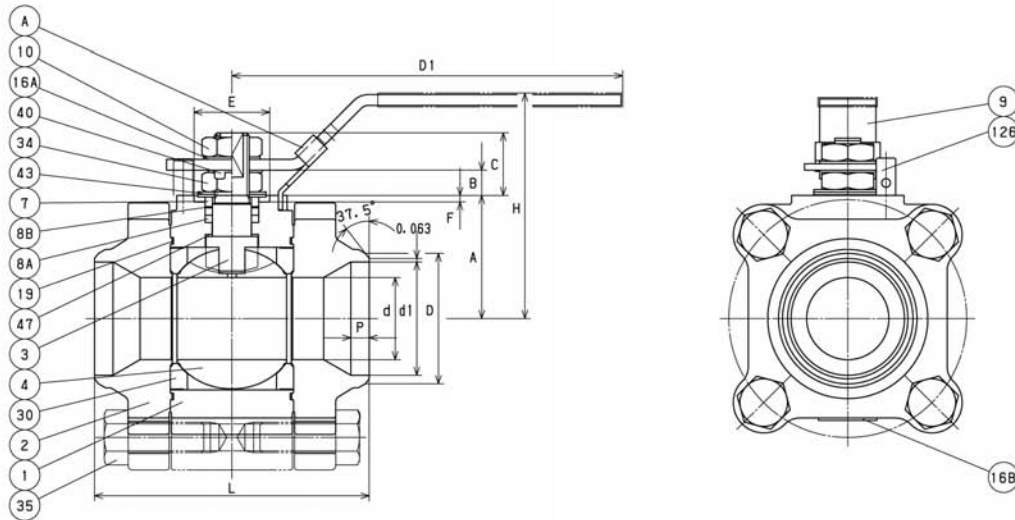

DIMENSIONS

Unit : mm

Nominal Size	Welding End										Mounting Dimensions for Actuator									
	in.	d	H	D1	L	d1	D	P	A	B	C	E	F	G	J	h	K	M	ISO 5211 Flange Type	
1 1/4	0.94	3.23	5.91	4.06	1.381	1.661	0.236	1.732	0.531	1.083	1.181	0.118	1.654	1/4-20UNC	0.315	M14	0.394	F04		
1 1/2	1.18	3.46	5.91	4.33	1.616	1.902	0.315	1.949	0.531	1.071	1.181	0.118	1.654	1/4-20UNC	0.315	M14	0.394	F04		
2	1.50	4.09	7.09	5.00	2.066	2.374	0.335	2.244	0.461	1.142	1.378	0.118	1.969	1/4-20UNC	0.394	M16	0.394	F05		

Unit : inch

Nominal Size	Welding End										Mounting Dimensions for Actuator									
	in.	d	H	D1	L	d1	D	P	A	B	C	E	F	G	J	h	K	M	ISO 5211 Flange Type	
1 1/4	0.94	3.23	5.91	4.06	1.381	1.661	0.236	1.732	0.531	1.083	1.181	0.118	1.654	1/4-20UNC	0.315	M14	0.394	F04		
1 1/2	1.18	3.46	5.91	4.33	1.616	1.902	0.315	1.949	0.531	1.071	1.181	0.118	1.654	1/4-20UNC	0.315	M14	0.394	F04		
2	1.50	4.09	7.09	5.00	2.066	2.374	0.335	2.244	0.461	1.142	1.378	0.118	1.969	1/4-20UNC	0.394	M16	0.394	F05		